



| | | | | |
|---|-------------|--|--|---------------|
| 10/05/2007 | B | Matière devient X2C-TiNb18 | VACLE | - |
| 25/09/2006 | A | EDITION ORIGINALE - Annule et remplace plan N°BEFP0229 | VACLE | - |
| DATE | IND. | MODIFICATIONS | AUTEUR | VERIFICATEUR |
| TOL GENERALES | | Designation: Boite distributrice pour câlots jetables |  BOURGEAT BP 19 - 38490 LES ABRETS - FRANCE Tel : (33) 04.76.32.14.44 Fax : (33) 04.76.32.25.66 | |
| Usinage/cutting: ± 1 | | | | |
| Pilage/bending: angles: ± 1° Lignes: ± 0.5 (1st) > 500 ± 1 (1st & 5) | | Ensemble/Set: Boite de distribution |  | |
| Entr point/punched pitch holes: < 1000: ± 0.5 > 1000: ± 1 | | | | |
| Ech/Scale | Format/size | Matière/Material | Ep /Thickn | Etat/Aspect : |
| 1:2 | A3 | X2C-TiNb18 | 12/10 | Gr220 |
| | | | N: 856100 | |





| | | | | | |
|---|-------------|--|--|--------------|-----------|
| 10/05/2007 | B | Matière devient X2CrTiNb18 | VACLE | - | |
| 25/09/2006 | A | EDITION ORIGINALE - Annule et remplace plan N°BEFP0230 | VACLE | - | |
| DATE | IND. | MODIFICATIONS | AUTEUR | VERIFICATEUR | |
| TOL GENERALES | | Désignation: Boite à gants | BOURGEAT BP 19 - 38490 LES ABRETS- FRANCE Tel:(33) 04.76.32.14.44 Fax:(33) 04.76.32.25.68 | | |
| Cisailage/cutting: ±1 Pliage/bending: angles: ±1° Cotes: <= 500: ±0.5 (1/2) > 500: ±1 (1/1.5) Entr.poin./punched holes: < 1000: ±0.5 > 1000: ±1 Méca./Mechanical: JS13 JS13 | | | | | |
| Ech/Scale | Format/size | Matière/Material | Ep./Thickn. | Etat/Aspect: | N: 856110 |
| 0.667 | A3 | X2CrTiNb18 | 12/10 | GR220 | |

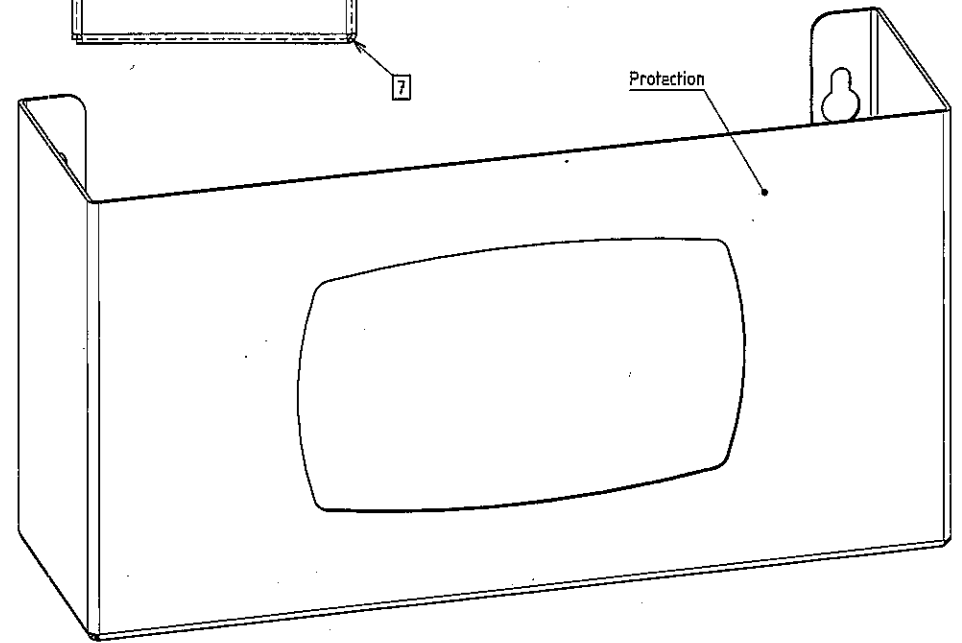
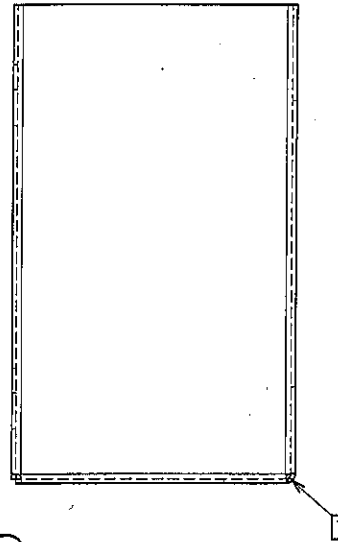
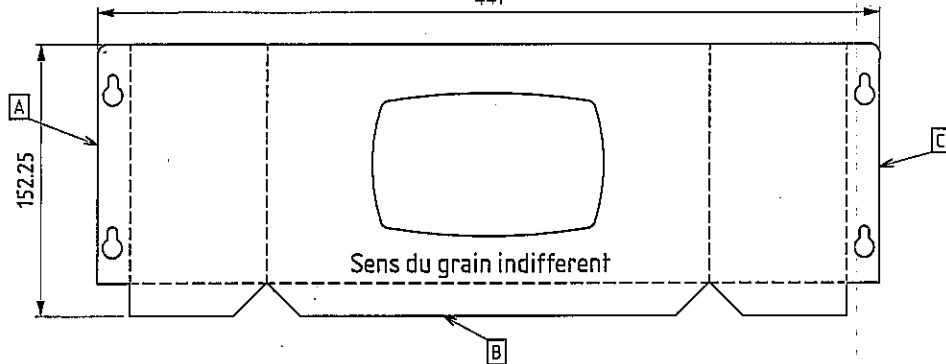
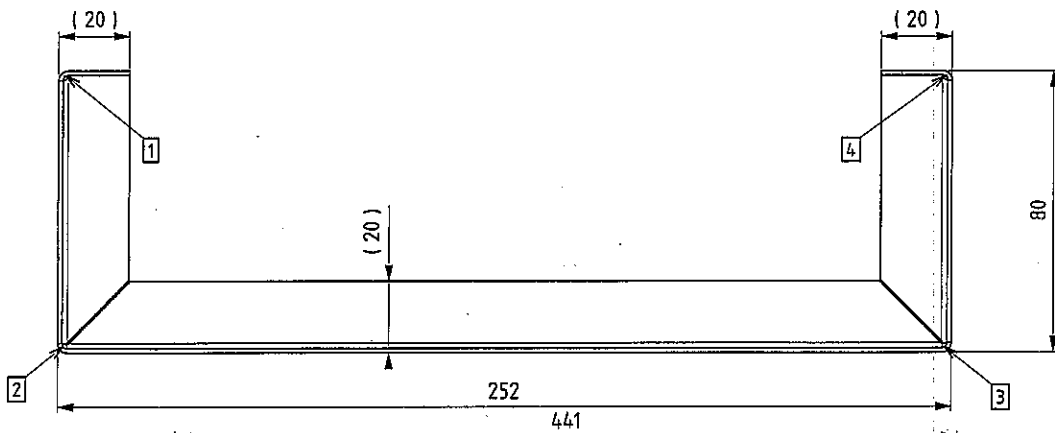
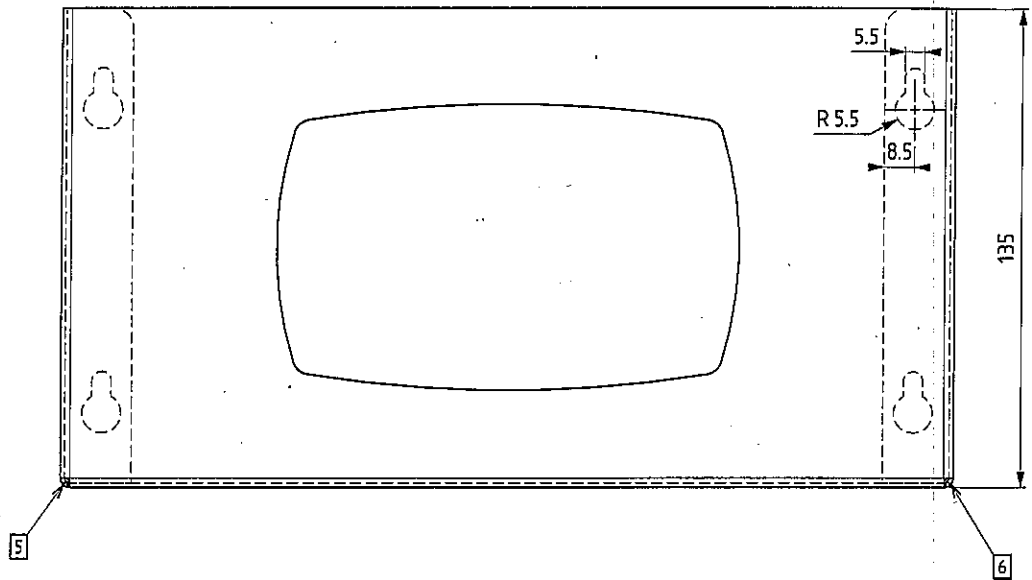
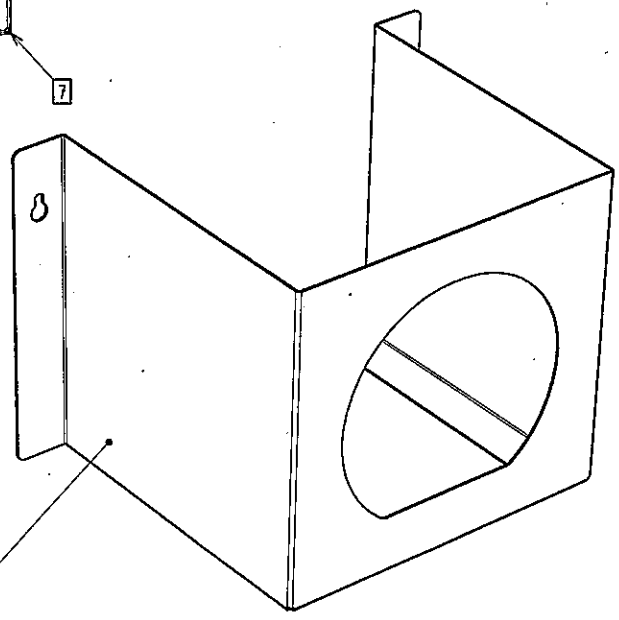
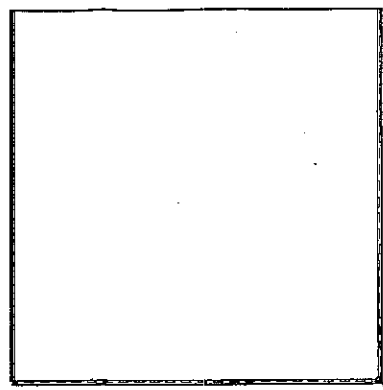
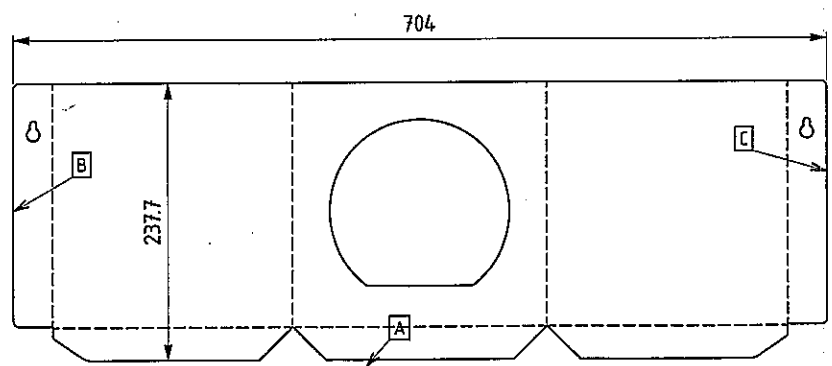
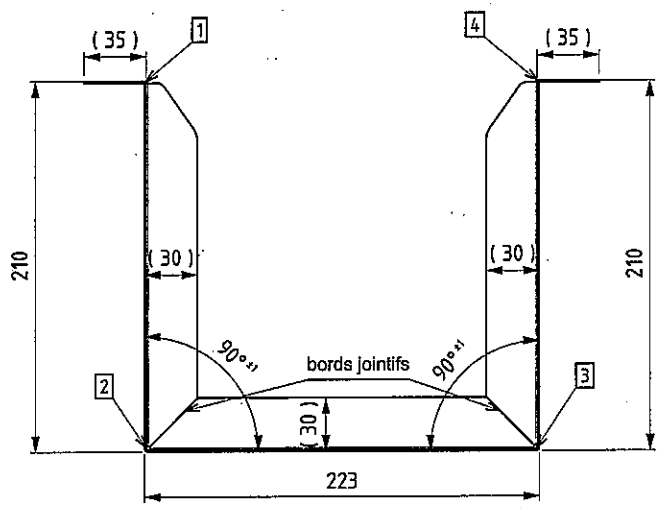
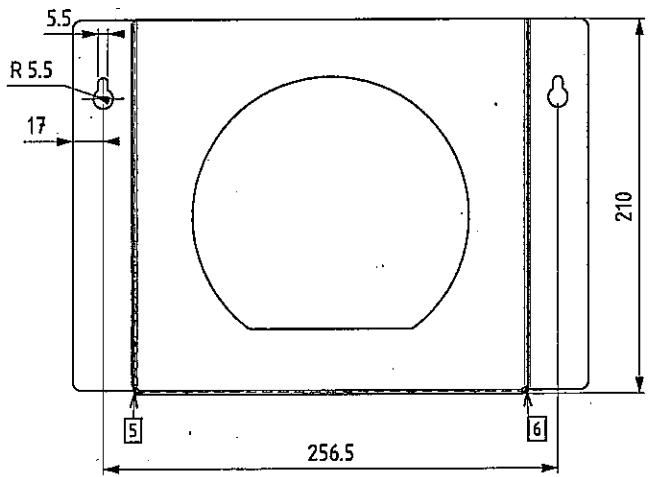

Sens du grain indifférent

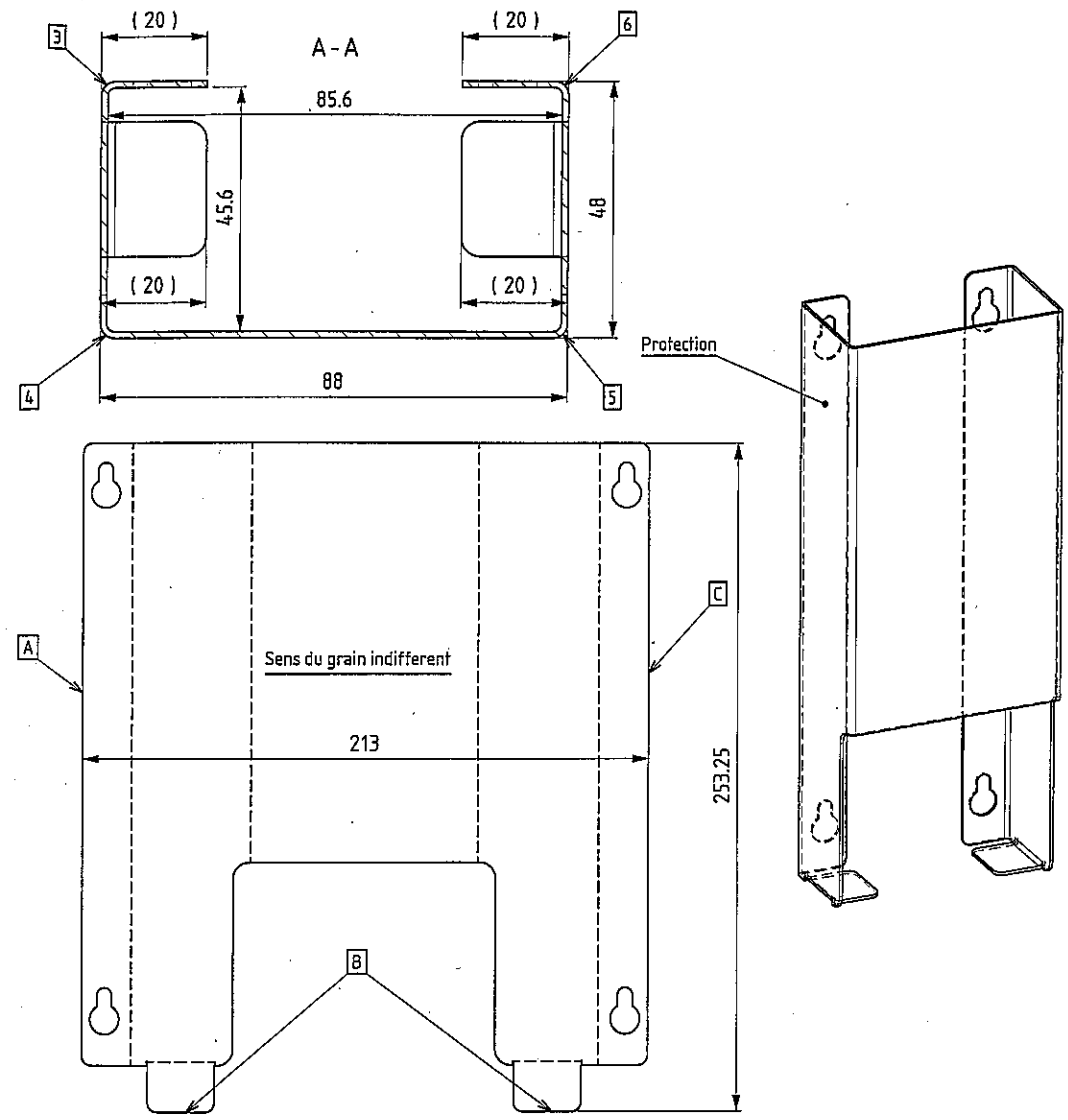
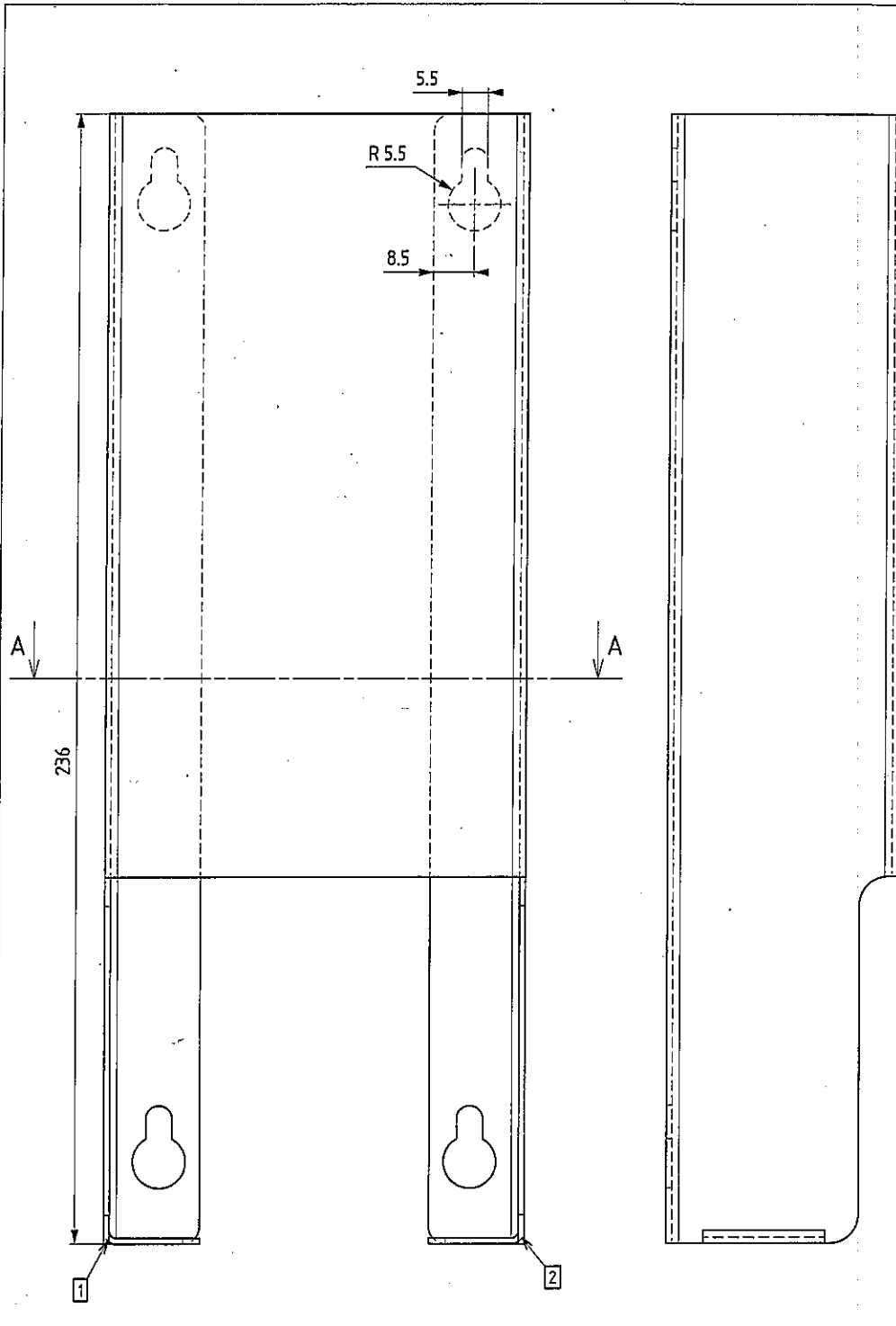
| | | | | | |
|--|-----------------|---|-------------------|---|-----------|
| 26/10/2009 | C | Modif d'im boîte 220->223 / SUPPRESSION SOUDURE / MODIF COTATION ANGLES | BOUVIER | - | |
| 10/05/2007 | B | Matière devient X2CrTiNb18 | VACLE | - | |
| 25/09/2006 | A | EDITION ORIGINALE - Annule et remplace plan N° BEFP0231 | VACLE | - | |
| DATE | IND. | MODIFICATIONS | AUTEUR | VERIFICATEUR | |
| TOL GENERALES | | Désignation: Boîte à charlottes | | BOURGEAT BP 19 - 38490 LES ABRETS- FRANCE Tél. (33) 04.76.32.14.44 Fax (33) 04.76.32.25.68 | |
| Usinage/cutting: ±1 Pliage/bending: angles: ±0.5 Cotes: <500 ±0.5 (1st) >500 ±1 (1st) 1.5 Enté poin./punched pitch holes: <1000: ±0.5 >1000: ±1 Méca/mechanical: J513-J515 | | Ensemble/Seh: BOITE DE DISTRIBUTION | | | |
| Ech/Scale: 1:3 | Format/size: A3 | Matière/Material: X2CrTiNb18 | Ep./Thickn: 12/10 | Etat/Aspect: GRAIN_220 | N: 856120 |



| | | | | |
|--|------|--|---|--------------|
| 10/05/2007 | B | Matière devient X2CrTiNb18 | VACLE | - |
| 25/09/2006 | A | EDITION ORIGINALE - Annule et remplace plan N°BEFP0228 | VACLE | - |
| DATE | IND. | MODIFICATIONS | AUTEUR | VERIFICATEUR |
| TOL GENERALES | | Désignation: Boite à masques |  BOURGEAT BP 19 - 38490 LES ABRETS- FRANCE Tél : (33) 04.76.32.14.44 Fax (33) 04.76.32.25.68 | |
| Usinage/cutting: ± 1 Pliage/bending: angles: ± 0.5 Colles: ≤ 500 ± 0.5 (1x1) > 500 ± 1 (1x1.5) Entr. poin./punched pitch holes: < 1000 ± 0.5 > 1000 ± 1 Méca/Mechanical: JS13 - js13 | | | | |
| Ech/Scale 1:1 | | Ensemble/Seh: Boite de distribution | Etat/Aspect: GRAIN_220 | |
| Format/size A3 | | Matière/Material X2CrTiNb18 | N: 856130 | |